

INSTALLING REGA & ORIGIN LIVE ARMS

Instructions by Origin live ©



Installation Instructions

Installation and Set up of Rega & Origin Live tonearms

INSTALLING THE ARM

INTRODUCTION

Rega arms and Origin Live arms require mounting dimensions such that the centre of the platter to the centre of arm hole is approx 223mm plus or minus 2mm tolerance and the hole diameter for the arm is 24mm to 25 mm.

Please note that for the Origin Live Silver 250 tonearms - do not adjust bearing tightness - this is carefully set at factory - it may seem that there is slight “play” in the bearings - this is deliberate and must be left alone or degradation will result - it is not actually play in the bearings but carefully designed clearance tolerances of other components.

VTA (VERTICAL TRACKING ADJUSTMENT)

To allow the cartridge needle to track at the correct angle it is important that the base of the arm is at the correct height in relation to the platter. Usually the optimum setting is such that the TOP edge of the arm is parallel with the surface of a FLAT record – you can use a piece of card with parallel lines drawn on it to check this once the cartridge is fitted.

Most cartridges have a height of 17mm and if this is the case, then the base of the arm should rest approximately 31mm below the top of the platter surface. If your cartridge height is different you can work out where the base of the arm should be from the preceding figures.

IF YOU DO NOT HAVE A VTA ADJUSTER

- If you do not have a VTA adjuster then use the 2 large spacing washers supplied to set the arm base to the correct height according to the above figures
- It is recommended to place the large serrated washer (supplied by Origin Live) under the large base nut as shown in the diagram “Rear end view of counterweight”. For decks with metal arm-boards (e.g the Gyrodeck) it sounds best NOT to fit the serrated washer - if in doubt listen to the difference. The washer does not always fit on the Rega 3 deck - if this is the case leave it off.
- Bolt the arm to the armboard or plinth - you only need tighten the large bolt to finger tightness or very slightly tighter (“nipped tight 1/16 turn”). It is best to experiment by listening to music. This may seem laborious but you will be richly rewarded as this adjustment is CRITICAL for performance. The mistake is often made of over tightening this nut with the result that the music is deadened.

IF YOU HAVE THE ORIGIN LIVE THREADED VTA ADJUSTER (WHICH FITS ALL DECKS)

Thread the adjuster onto the arm. Ensure that the threaded metal sleeve is the right way up with the recess on the top side. This ensures that the arm goes all the way down into the sleeve. If you find your arm is too high with fitted then you should remove it as it adds 1.5mm to the height of the arm. As a starting point set up the arm such that it is parallel with a FLAT record, if not rotate the VTA adjuster at the arm base to get the level right.

It is recommended to place the large serrated washer (supplied by Origin Live) under the large base nut as shown below. For decks with metal armboards (eg the Gyrodeck) it sounds best NOT to fit the serrated washer - if in doubt listen to the difference. The washer does not always fit on the Rega 3 deck - if this is the case leave it off.

Bolt the arm to the armboard or plinth - you only need tighten the large bolt to finger tightness or very slightly tighter (“nipped tight 1/16 turn”). It is best to experiment by listening to music. This may seem laborious but you will be richly rewarded as this adjustment is CRITICAL for performance. The mistake is often made of over tightening this nut with the result that the music is deadened.

If your armboard is less than 10mm thick you will need to fit an arm “packing washer” between the armboard and the large bolt or it will not “clamp” on the 4mm thick armboard.

IF YOU HAVE THE ORIGIN LIVE VTA SLIDING ADJUSTER

Do not fit a threaded VTA adjuster. Ensure that the Aluminium sleeve is the right way up with the recess on the top side. This ensures that the arm goes all the way down into the sleeve. Place the arm in the aluminium sleeve and then clamp it in position via the set screw in the side of the VTA housing (i.e. the sleeve is forced in to grip the arm's threaded base). You do not need the Rega nut on the base of the arm. Only tighten the set screw sufficiently to clamp the arm firmly in position – over-tightening can make the arm sound bright..

FIT THE ARM CABLE CLIP

Fasten the arm cable - this should be supported by a cable clip screwed into position underneath the plinth - leave a slight droop on it so that it isn't "tight". This again is helpful to "earth" vibration in the cable. (Please note that the occasional rewired arm can make a slight "rustling" noise through the speakers when it is lifted across the record. This should not be a cause for concern as it is only caused by microphony of the internal litz cable - under normal playing conditions this is inaudible. The earth lead should be connected to the earth of your pre-amplifier or amplifier. This earth lead is best separated slightly from the arm signal leads so do not wind it around them for best performance. Avoid pulling the external wires at the base of the Silver arms as they are not indestructible and can become detached if excessive force is used to manipulate them.

ARM & CARTRIDGE SET UP

FIT THE CARTRIDGE (IF NOT FITTED ALREADY)

Fit the cartridge to the arm using an alignment gauge and ensure the headshell wires are bent so that they are clear of the record surface. If you are not familiar with fitting cartridges then please read the section "Hi-Fi Cartridges – Setting up procedures".

SET TRACKING FORCE & SIDE FORCE BIAS

Ensure that the bias adjustment slider is set to zero. Set the tracking force to the manufacturer's recommendations using a stylus force gauge (stylus balance). When tightening the counterweight, set it so that the Allen bolt is at the side of the arm (not at the top) see figure "Rear end view of counterweight" and tighten firmly - check tracking force is still correct after tightening.

Once the tracking force has been set you can set the sliding control for tracking bias - This should be set to be approximately equal to the tracking weight value. The settings you read on the arm are not always dead accurate so it may be worthwhile to fine tune the setting by ear using the centre track of a record.

USE OF STYLUS FORCE GAUGE

Most stylus force gauges work on the same principle as a set of scales or balances. For example with the Ortofon Stylus Force Gauge, first place the stylus on the inscribed or graduated portion of the scales. Then try the stylus at different points until you find the point where the beam "balances" freely in a roughly level position. You then read the force that is being exerted – (1gram = 10 mN if the scale is in mN). From this number you can assess whether you need to increase the tracking force or vice-versa. Move the tonearm counterweight accordingly and re-measure the tracking force. Repeat this procedure until the correct tracking force is obtained. The Shure stylus force gauge works slightly differently so follow the instructions that come with the gauge.

SET THE VTA (VERTICAL TRACKING ADJUSTMENT)

To allow the cartridge needle to track at the correct angle it is necessary that the base of the arm is at the correct height in relation to the platter. Usually the optimum setting is such that the TOP edge of the arm is parallel with the surface of a FLAT record – you can use a piece of card with parallel lines drawn on it to check this. Place the cartridge on the record with the deck switched off. Hold the card edge onto the record in a position alongside the arm and see whether the top edge of the arm is parallel. Raise or lower the base of the arm till you achieve parallel position. Most cartridges have a height of 17mm. If this is the case, the base of the arm should rest approximately 31mm below the top of the platter surface – see diagram "cross-section of sub-chassis".

It is worth experimenting with VTA adjustment. Slightly raise or lower the arm and then listen - if the sound is relatively bright then the arm is too high, if it is relatively dull and bass heavy then the arm is too low.

- **If you have no VTA adjuster** Raise and lower the arm by fitting spacing washers under the arm. Alternatively you can raise or lower the height of the platter – this is easily accomplished by removing the

platter & sub-platter to re-set the height of the threaded bearing house (see “diagram showing threaded bearing house arrangement”).

- **If you have the threaded VTA adjuster** Raise and lower the arm by rotating the VTA adjuster. If you find your arm is too high in relation to the platter with the VTA adjuster set to give the arm it's lowest position then you need to raise the height of the platter a few millimetres – this is easily accomplished by removing the platter & sub-platter to re-set the height of the threaded bearing house (see “diagram showing threaded bearing house arrangement”).
- **If you have the Origin Live VTA sliding adjuster** – Raise and lower the arm in the aluminium sleeve and then clamp it in position via the set screw in the side of the VTA housing (i.e the sleeve is forced in to grip the arm's threaded base). You do not need the Rega nut on the base of the arm. Only tighten the set screw just sufficiently to clamp the arm in position – over-tightening can make the arm sound relatively bright.

SET THE ARM FASTENING TIGHTNESS

It is best to experiment with the tightness of the large Rega base nut (if fitted) by listening to music. This may seem laborious but you will be richly rewarded as this adjustment is CRITICAL for performance. The mistake is often made of over tightening this nut with the result that the music is deadened.

NOTES

A detailed description of Cartridge set up and care is included in the end sections of this manual.

Please note that the occasional rewired arm can make a slight “rustling” noise through the speakers when it is lifted across the record. This should not be a cause for concern as it is only caused by microphony of the internal litz cable - under normal playing conditions this is inaudible.

The earth lead should be connected to the earth of your pre-amplifier or amplifier. This earth lead is best separated slightly from the arm signal leads so do not wind it around them for best performance.

We guarantee arms supplied by ourselves to be free from fault for 2 years and will undertake to correct any faults providing the arm has not been modified by any party other than ourselves and has not received maltreatment of any kind.

Now that all the hard work is over you can settle back and hear the results - we wish you many hours of enjoyable music and rediscovering your record collection. Fit the cartridge to the arm using an alignment gauge and ensure the headshell wires are bent so that they are clear of the record surface. Ensure that the bias adjustment slider is set to zero. Set the tracking force to the manufacturer's recommendations using a stylus force gauge (stylus balance). When tightening the counterweight, set it so that the Allen bolt is at the side of the arm (not at the top) see figure below and tighten firmly - check tracking force is still correct after tightening.

Set the sliding control for tracking bias - This should be set to be approximately equal to the tracking weight value. You can then fine tune the setting by ear using the centre track of a record as the calibration is not always dead accurate.

It is worth experimenting with VTA adjustment if you can. Slightly raise and lower the arm and then listen - if the sound is bright then the arm is too high, if it is dull and bass heavy then the arm is too low.

We guarantee arms to be free from fault for 2 years and will undertake to correct any faults providing the arm has not been modified by any party other than ourselves and has not received maltreatment of any kind.

NOTE: The Ortofon stylus force gauge works on the same principle as a set of scales or balances. First, place the stylus on the inscribed line on the white portion of the scales. Then try the stylus at different points along the line until you find the point where the white plastic beam “balances” freely in a roughly level position. You then read the force that is being exerted - 1gram = 10 mN on the numbered scale, . From this number you can assess whether you need to increase the tracking force or vica-versa. Move the tonearm counterweight accordingly and re-measure the tracking force. Repeat this procedure until the correct tracking force is obtained.

A detailed description of Cartridge set up and care is included in the end sections of this manual.

REAR END VIEW OF COUNTERWEIGHT

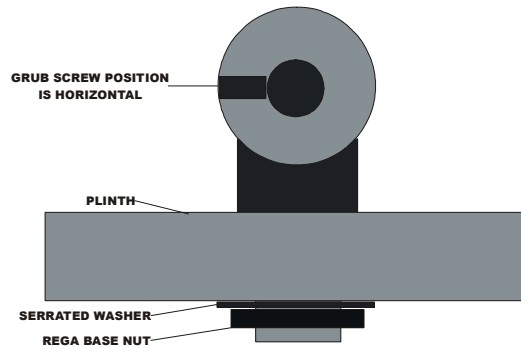

Hi-Fi cartridges - setting up procedures

INTRODUCTION

GENERAL NOTES

As we supply most makes of hi-fi cartridge we get asked questions from time to time about various issues regarding set up and care. To help newcomers to this area we have published the following notes. These guidelines are of a general nature - we publish them only to be of help and although widely accepted they are not formally authoritative - we cannot accept liability if you choose to use them and neither do we encourage the time consuming occupation of answering queries surrounding the procedures outlined - these are best referred to the manufacturer of your specific hi-fi cartridge.

For those new or inexperienced to fitting hi-fi cartridges we would state that this is NOT difficult and much of the detail and perfectionism outlined below is for those who like to experiment. We ourselves do not normally check azimuth, or vary tracking forces from the manufacturers recommendations - neither would we worry if the arm was up to 3mm away from the recommended distance from the spindle - although all these details are audible they are generally of a relatively low order, although tracking force and VTA are worth trying should you feel anything is lacking. If things seem complicated we would encourage you not to be put off as it all becomes clear once you get started.

Before fine tuning the set up as described below you should allow the cartridge to "run in" properly - at least 40 hours for some cartridges.

IMPORTANCE OF OVERALL SET UP

Hi-Fi cartridges travel like a bobsleigh through the grooves of a record only a few thousandths of an inch wide. You hear groove displacements of the order of a few millionths. (That's like splitting a hair into one thousand pieces.) Every bit of motion or vibration allowed at this level can be heard enormously amplified through your speakers. For this reason it is good to set up the turntable and arm correctly so that the audio cartridge can do it's job properly. For instance a turntable out of level can produce side forces on the pickup cartridge tip that will wear it more on one side than the other as well as have a slightly degrading effect on the wear of your records.

LEVELNESS

When a turntable goes out of level, the platter bearing performance and the arm's dynamics, specifically anti-skate, are negatively affected. So be sure your turntable platter and tonearm mounting board are level - use a spirit level. If the platter is out of level, first adjust the surface that the deck stands on. The suspension (in the case of a suspended sub-chassis design) may also need levelling if it has subsided over time. If the arm board is not level (which means the arm pivot is not vertical), either return it to your dealer for repair or re-level it yourself by shimming between the mounting board and it's support.

HI-FI CARTRIDGES ALIGNMENT

Alignment for hi-fi cartridges needs to be optimised in three different planes. However, it cannot be perfect in all three planes, so it must be optimised for an overall best balance or compromise. The final authority should always be

your ears and preferably over an extended period of listening time. Bear in mind that each record is cut slightly differently. Here again, optimise for an overall balance of good sound over a wide range of records. The three alignment planes are as follows. (Please note that it is the stylus, not the cartridge that is being aligned.)

- **Lateral tracking angle**

Viewed from above, the hi-fi cartridges arcing movement across the record must maintain the stylus in the same relation to the groove as that of the cutting stylus's straight-line tracking; this is Lateral Tracking Angle, or Tangency. Apart from linear tracking arms this is always a matter of the best compromise.

- **Azimuth**

Viewed from head on, the stylus must be perpendicular in the groove so as not to favour one groove wall, and therefore one channel, over the other wall/channel; this is Azimuth.

- **Vertical tracking angle (VTA)**

Viewed from the side, the stylus must sit correctly in the groove, at the same angle as the original cutter; this is Vertical Tracking/Stylus Rake Angle. (VTA, however, varies from record to record. Therefore, this alignment must be set by ear, even more than is the case with the other adjustments.) Also check that the distance from the centre of the arm pillar (the upright post) to the spindle (usually fixed by the arm mounting board) is correct as this will affect the ability to achieve the tangency adjustments. This "L dimension varies with every pivoted arm — check your manual or with the manufacturer (in the case of Rega arms this measurement is 222mm).

HI-FI CARTRIDGE ALIGNING TOOLS

Tools required are an alignment gauge, a tracking force gauge, a FLAT record, a screwdriver or Allen keys of the right size (usually 2mm), a good light may also be helpful. Small needle-nose pliers and a magnifying glass all help. It also helps to have the hi-fi news test record. Treat the arm with care as some parts are fragile. To this end ensure that tightening of any bolts is carried out gently and without causing undue strain. Do not adjust bearing tightness - this is carefully set at factory - it may seem that there is slight "play" in the bearings - this is deliberate and must be left alone or degradation will result - it is not actually play in the bearings but carefully designed clearance tolerances of other components. Check hi-fi cartridge clip connections and mounting

Tonearm wiring uses a standard color code for channel and polarity ID: White = L Hot, Blue = L Ground, Red = R Hot, and Green = R Ground. If the cartridge pins aren't color-coded the same way, they will have letter identifications next to them. Make sure that the arm's wires, wire clips, and solder joints are in very good condition. At minimum, clean the contact between cartridge pins and wire clips by removing and replacing each clip. Holding the clips with needle-nose pliers can make this easier, but be careful that you don't strain the wires where they join the clip. Check the clips for a proper fit on the cartridge pins, and adjust them if necessary. "Proper" means snug but not tight. To check clip size, hold the cartridge tail-up close to the head wires, grasp a clip firmly right behind its tubular part with the tweezers, line it up with the cartridge pin, and press. If it does not slide on with moderate force, the clip needs opening-up. If it slides on easily but flops around when attached, it needs tightening. Sizing is the operation most likely to detach a clip. The trick is to avoid bending the wire at its attachment point or putting too much tension on it. To avoid either, always hold the clip with its wire slightly slack-looped behind it while adjusting. For opening a clip, hold it firmly with the tweezers or needle-noses, right behind its tubular section, and press the tip of the jeweler's screwdriver into the open end of its longitudinal slot until you see this widen very slightly. (Here's where you'll probably need the headband magnifier or reading glasses.) You're dealing with thousandths of an inch here, so a barely visible spreading may be all that's needed. Try it for fit, and repeat until it does. For tightening a clip, press a toothpick inside it as far as it will go, then use the needle-nose pliers to gently squeeze together the sides of the clip near its free end, while watching the slot for any change. (Attempting to squeeze a clip without the toothpick inside it will flatten its sides.) Try it for size, and resqueeze if necessary until the fit is correct. When it is, close up the middle section of the tube to match the end

Cartridge mounting screws (usually 2.5mm allen bolts) should be tight. Steel allen bolts are the best for mounting hi-fi cartridges - aluminum or brass are OK but difficult to tighten.

FITTING THE HI-FI CARTRIDGE

MOUNTING

Mount the hi-fi cartridge in the headshell if this is not done already. This is best done with the hi-fi cartridge stylus guard in place but it may be necessary to remove it during at least one phase of the installation. If you do, replace it as soon as possible. Be especially careful when the stylus guard is off, as many MC cartridges have a strong magnetic field at the base of the cantilever. If this attracts the tip of a steel-bladed screwdriver, it can destroy the stylus - there is no hope of resisting it. The best precaution is to keep the screwdriver well away from the cantilever, use a nonferrous

screwdriver, or keep the stylus guard on when you're using the screwdriver near it. The headshell screws should be finger-tightened just enough that the cartridge cannot fall off but is still loose enough that the cartridge is easily moved around. Work whenever possible with the stylus's safety cap in place. Set tracking force at nominal, then do the tangency alignment procedures, then the azimuth. Do not deviate from this sequence as each step affects the subsequent one — change the order and the setup will be wrong.

TRACKING FORCE

This adjustment is carried out on the counterbalance weight of the tonearm or spring dial if one is in place. At this point, use your tracking force gauge and setting tracking force according to your cartridge instructions — final adjustment will be done later by ear. If you do not have a tracking force gauge, but the arm does have a calibrated counterweight, defeat the arm's anti-skate mechanism or set it to zero. Set the counterweight so the arm is level and balanced. Be very careful of the unprotected stylus — you cannot do this with its safety cap in place. Once the arm is balanced, lock it in its cradle and, using the calibrated counterweight, set the tracking force according to your cartridge's recommended weight.

TANGENCY ALIGNMENT (LATERAL TRACKING ANGLE)

Follow the manufacturer's literature and the dictates of your alignment gauge — different gauges use slightly different methods. As you square up the hi-fi cartridge body with the gauge's markings, be sure that the cartridge sides are square or your alignment will be wrong. When all adjustments are correct, carefully tighten down the hi-fi cartridge mounting screws. Keeping a firm grip on hi-fi cartridge and headshell together so nothing shifts, delicately tighten each screw down a turn or so, then repeat until tight. Tightening down one screw all the way before tightening the others is almost certain to twist the cartridge out of alignment. However careful you've been, always check the alignment again after tightening.

VERTICAL TRACKING ANGLE (VTA)

Unless your tonearm has a special VTA adjuster, adjusting arm height is usually carried out with the use of spacing washers (as with Rega arms). In arms with a pillar / collar type vta adjuster it helps to put pencil or pen marks on the pillar to keep track of various heights. See your tonearm manual for its recommendations on adjusting arm pillar height. The best approach is to tune-in VTA gradually by listening to music. You know the arm needs to be lowered at the arm pillar when the overall sound is hard and bright, with thin bass or no deep bass, edgy highs, and harsh midrange (of course, this could also be tracking force which is too light). Distortion obscures low level details between the musical; notes so dynamic range is reduced. Transient attacks may be too sharp. Raise the arm when the sound is dull and damped, the highs rolled off, the lows muddy and lacking definition, and transient attacks are dull. Mind you, this sounds an awful lot like the effects of changes in tracking force (too light is edgy, too heavy is heavy and dull). They are different sounding but hard to explain. Start with the arm a little low and very gradually raise it, first to where it is parallel to the record, and then so the back of the cartridge is tilting up. Keep track of your settings so you can return to the one you like best where everything snaps into focus. The range of adjustments can be quite broad, as much as 3/4" or even more (at the arm pivot). Play with the full range so you know what it sounds like and don't be diffident.

ANTISKATE FORCE (PIVOTING ARMS ONLY)

This applies an opposing, balancing force to the natural inward drag of a pivoting arm while playing. Left uncontrolled, the stylus would push up against the inner groove wall, causing distortion both from mistracking and a cantilever skewed in relation to the cartridge generator. To set, lower the stylus down near the label of a record with a wide run-out to it. Increase antiskate until the arm starts to slowly drift outward, away from the label. Again, this should be finalized by ear as you listen to music. If image placement is a little off-center, or if things don't seem to be locked in solidly, experiment with antiskate. Also, watch the stylus when you set it into a groove. Does it move to the right or left relative to the cartridge body? This indicates too much or too little antiskating.

FINE TUNING

You now have three adjustments approximated. Tracking force, VTA, and azimuth. It's a matter of reiteration to optimize the sound. The change in sound with each of these individual adjustments can be similar. It's therefore necessary, in optimizing all three, to experimentally move from one type of adjustments to the next, then to the next, in order to balance the optimization for all three. It's helpful to listen to female vocals as you proceed. Firstly try deviating from the cartridge's recommended tracking force by small increments - about 0.2 of a gram deviation above and below the manufacturer's basic recommendations. Don't worry about record damage from heavy tracking as most record damage is actually caused by mistracking in the middle-to-high frequencies with too little tracking force rather than with too heavy. If you're getting mistracking at the low (lightest) end of the range and yet the low range is

generally sounding the best (and on moderate signals, not heavy passages), then chances are you have either a dirty stylus, a bad record, an accumulation of crud in your cartridge, or a cartridge that's getting old. Changes in tracking force can change how you want VTA and azimuth adjusted. If azimuth was initially adjusted by ear, experiment with it.

Proper care and maintenance of Hi-Fi cartridges & records

CARE OF HI-FI CARTRIDGES

Replace your cartridge when due - hi-fi cartridges have a lifespan for their cantilever suspensions and stylus needles. This will vary from manufacturer and type of cartridge as well as other factors like the cleanliness of your record and the care you take of the cartridge. It is wise to enquire on the expected life of your cartridge to the manufacturer so that when the time comes it is replaced accordingly - most importantly this will preserve your records as well as enable you to enjoy the best performance.

If there is a build-up of dust and dirt where the needle enters the cartridge body you should use a small soft brush to brush the debris out. Always brush from the direction of the cantilever to the stylus or you may do damage.

Care of stylus - One well known method of cleaning stylus is the Linn green stuff which is a very fine abrasive paper - this may just be OK on some cartridges which do not have fine stylus tips and fragile cantilever mechanisms. However there is a danger of causing fractures or chips on your diamond stylus on certain fineline tips. This method can also strain the cantilever mechanism.

There are a number of fluids on the market that increase stylus life and help to clean gunge from the needle - a word of caution though - some of these can loosen the stylus glue on the cantilever over time - some fluids can also attack the cantilever or coil material itself or harden the suspension - consult your cartridge manufacturer over this. One key factor is to use the liquid very sparingly on a cotton bud such that it is just damp (not running with fluid) - this minimises the fluid which can run up inside the cartridge.

RECORD CARE AND CLEANING

The stylus itself does a pretty good job of cleaning the grooves and should itself therefore be kept clean. The proprietary brushes etc. for cleaning records will often do little more than brush dirt deeper into the record grooves and are best avoided if possible. Also keep records in high quality non-scratch record sleeves - preferably good ones.

A record cleaning machine is really the only answer for cleaning records properly as they suck out the debris and dust in the record grooves using a powerful vacuum. Tests using a microscope prove that this does the job with 100% success. The performance improvement is also very noticeable when it comes to even new records being played. We supply and highly recommend the Moth record cleaning machine as this is very effective from personal experience and comes with many glowing endorsements – see our web site for details and reviews.

Word/ instructions/ turntable and arms/ tonearm installation instructions

ORIGIN LIVE, Unit 5, 362b Spring Road, Sholing,, Southampton, SO19 2PB U.K.
Tel:- 02380 578877 Fax:- 02380 578877 Owner:- Mark Baker C.Eng, BSc(Hons)MRINA
e mail: originlive@originlive.com web site: <http://www.originlive.com>